

**Biology**  
**Standard level**  
**Paper 2**

Wednesday 4 May 2016 (morning)

Candidate session number

1 hour 15 minutes

--	--	--	--	--	--	--	--	--	--

**Instructions to candidates**

- Write your session number in the boxes above.
- Do not open this examination paper until instructed to do so.
- Section A: answer all questions.
- Section B: answer one question.
- Write your answers in the boxes provided.
- A calculator is required for this paper.
- The maximum mark for this examination paper is **[50 marks]**.



### Section A

Answer **all** questions. Write your answers in the boxes provided.

1. During the development of multicellular organisms, cells differentiate into specific cell lines. A study was carried out on the early stages of differentiation in cells from mouse embryos that were grown in cultures. Two differentiated cell lines were studied, one of inner embryonic tissue (endodermal cells) and the other of external embryonic tissue (nerve cells) after 48 and 96 hours of incubation in cell cultures. A culture of undifferentiated cells was used as a control group. Cell population growth was measured by changes in cell density in all three cell lines.

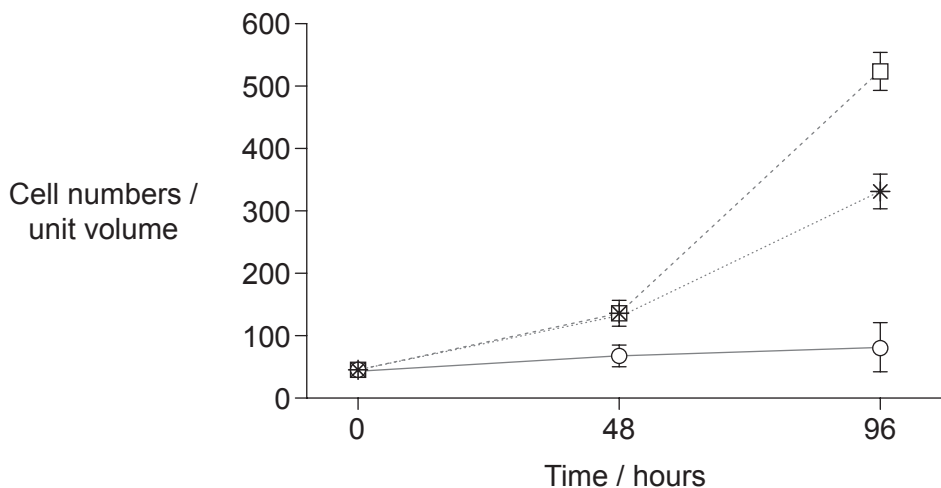

**Key:** --□-- control cells (undifferentiated)    \* endodermal cells    -○- nerve cells

[Source: V. Bryja, J. Pacherník, J. Vondráček, K. Souček, L. Čajánek, V. Horvath, Z. Holubcová, P. Dvořák and A. Hampl. "Lineage specific composition of cyclin D-CDK4/CDK6-p27 complexes reveals distinct functions of CDK4, CDK6 and individual D-type cyclins in differentiating cells of embryonic origin". *Cell Proliferation*, Vol 41, Issue 6 (pages 875-893). <http://onlinelibrary.wiley.com/doi/10.1111/j.1365-2184.2008.00556.x/epdf>]

- (a) Distinguish between the changes in cell numbers in the three cell lines that occur during the 96 hour period. [2]

.....

.....

.....

.....

.....

.....

(This question continues on the following page)



**(Question 1 continued)**

- (b) Using the data in the graph, deduce the relationship between cell differentiation and population growth.

[1]

.....

.....

**(This question continues on the following page)**



**(Question 1 continued)**

There are three phases of interphase in the cell cycle:

- the growth phase with the synthesis of RNA and proteins (G1)
- the phase of DNA replication (S)
- and the pre-mitotic phase of rapid growth (G2).

The graph shows the percentage distribution of the three cell lines in the different stages of interphase after 96 hours of incubation.

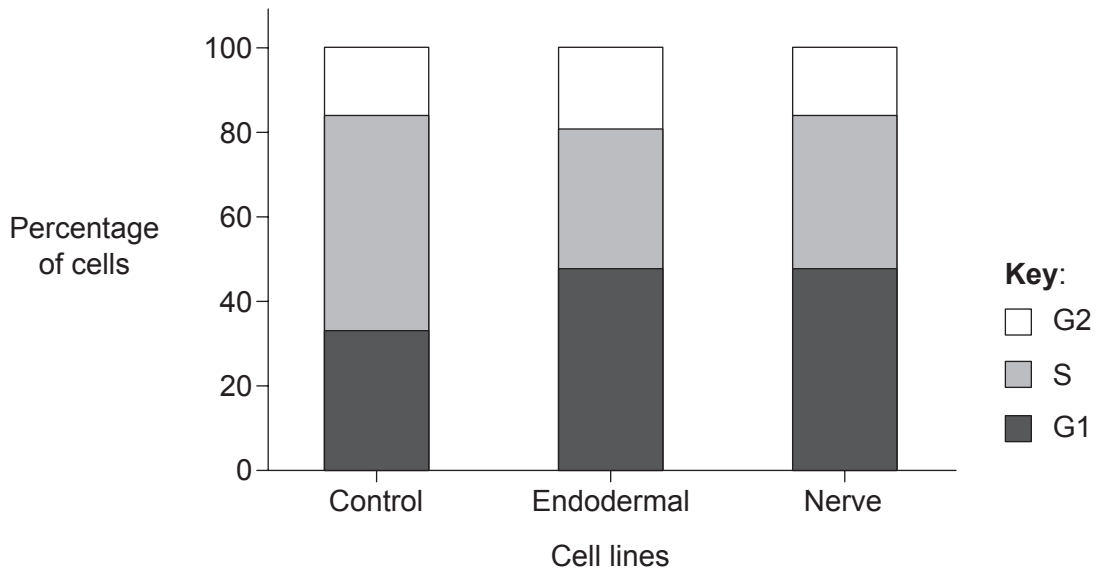

[Source: V. Bryja, J. Pacherník, J. Vondráček, K. Souček, L. Čajánek, V. Horvath, Z. Holubcová, P. Dvořák and A. Hampl. "Lineage specific composition of cyclin D–CDK4/CDK6–p27 complexes reveals distinct functions of CDK4, CDK6 and individual D-type cyclins in differentiating cells of embryonic origin". *Cell Proliferation*, Vol 41, Issue 6 (pages 875–893). <http://onlinelibrary.wiley.com/doi/10.1111/j.1365-2184.2008.00556.x/epdf>]

(c) Compare and contrast the percentage of control and nerve cells in each of the three phases after 96 hours of incubation.

[2]

.....

.....

.....

.....

.....

.....

**(This question continues on the following page)**



**(Question 1 continued)**

- (d) Using the data of both graphs, deduce the relationship between the percentage of cells in each cell cycle phase and the population growth. [2]

.....  
.....  
.....  
.....

- (e) Interphase is followed by mitosis. State the final product of the mitotic cell cycle. [1]

.....

**(This question continues on the following page)**



**(Question 1 continued)**

The role of regulators in the different stages of differentiation was also studied. After 96 hours of incubation a sample was taken of each cell line and the cyclins separated by gel electrophoresis. The presence of different cyclins D1, D2 and D3 was analysed in the three cell lines. The image shows the results. The size and the intensity of the band is an indicator of the quantity of cyclins.

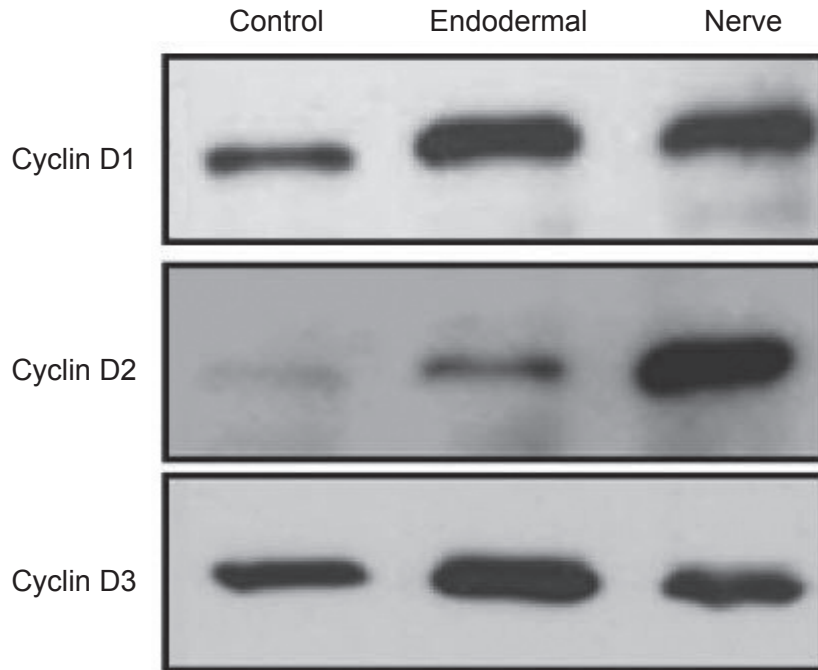

[Source: V. Bryja, J. Pacherník, J. Vondráček, K. Souček, L. Čajánek, V. Horvath, Z. Holubcová, P. Dvořák and A. Hampl. "Lineage specific composition of cyclin D–CDK4/CDK6–p27 complexes reveals distinct functions of CDK4, CDK6 and individual D-type cyclins in differentiating cells of embryonic origin". *Cell Proliferation*, Vol 41, Issue 6 (pages 875–893). <http://onlinelibrary.wiley.com/doi/10.1111/j.1365-2184.2008.00556.x/epdf>]

(f) Compare and contrast the amounts of the different cyclins in nerve cells and control cells.

[2]

.....

.....

.....

.....

.....

.....

**(This question continues on the following page)**



**(Question 1 continued)**

- (g) Using the data, discuss the possible roles of the three cyclins in the differentiation of nerve and endodermal cell lines.

[3]

.....

.....

.....

.....

.....

.....

.....

.....

.....

.....



2. The image shows a nomogram.

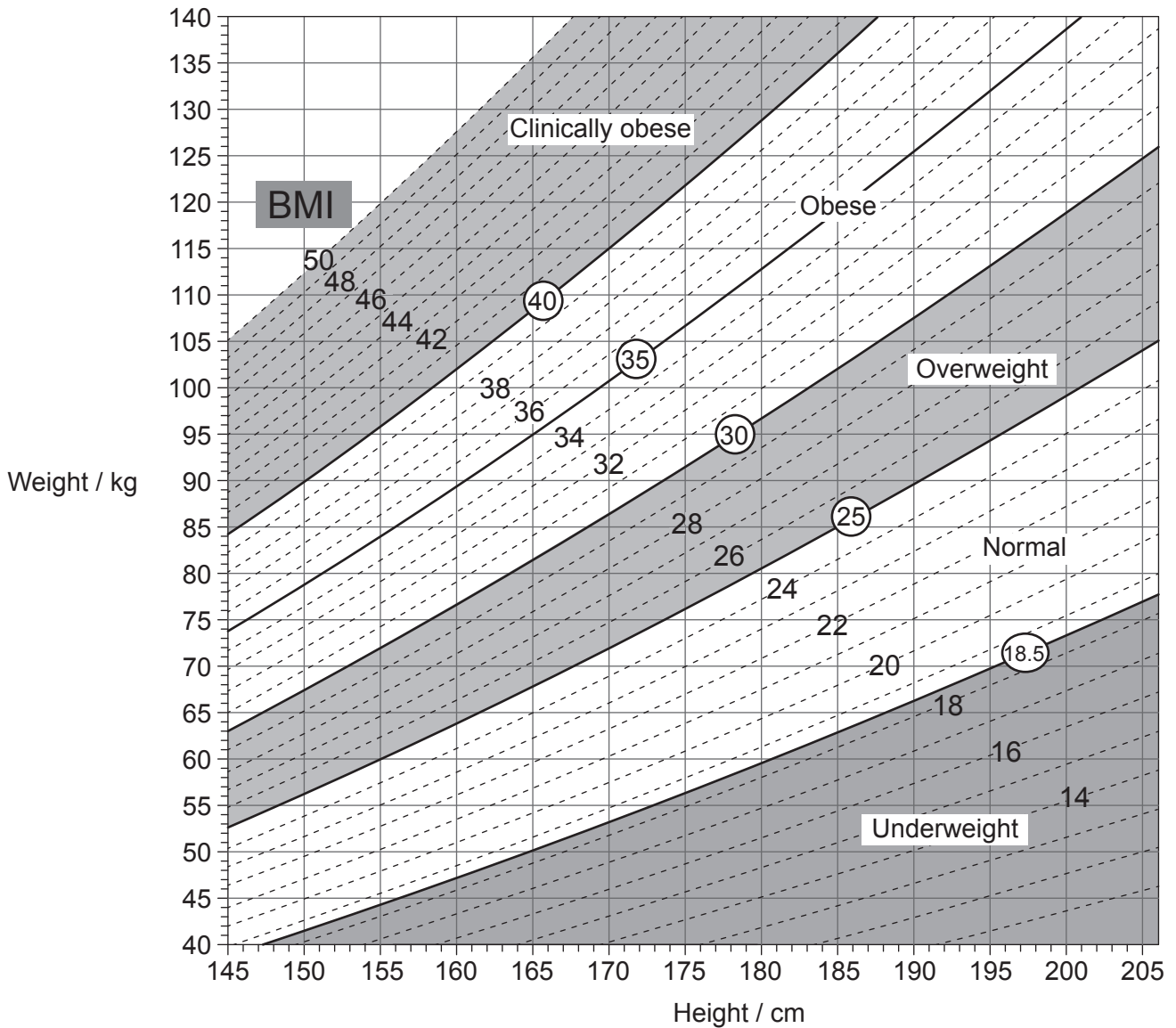

[Source: © All rights reserved. *Canadian Guidelines for Body Weight Classification in Adults*. Health Canada, 2003. Adapted and reproduced with permission from the Minister of Health, 2016.]

(a) (i) Using the nomogram, state the lower weight limit for a woman with the height of 155cm who is classified as overweight, giving the units.

[1]

Lower weight limit: .....

(This question continues on the following page)





**(Question 2 continued)**

(ii) State a major health problem of the circulatory system that is correlated with obesity. [1]

.....  
.....

(b) Draw the structure of a saturated fatty acid. [2]

(c) Describe how the hormone leptin helps to prevent obesity. [3]

.....  
.....  
.....  
.....  
.....  
.....  
.....  
.....



3. (a) (i) Distinguish between the thermal properties of water and methane. [2]

.....

.....

.....

.....

.....

.....

(ii) Explain the reasons for the unique thermal properties of water. [2]

.....

.....

.....

.....

.....

.....

(This question continues on the following page)



**(Question 3 continued)**

- (b) Using the diagram, explain the interaction of short and long wave radiation with greenhouse gases in the atmosphere.

[3]

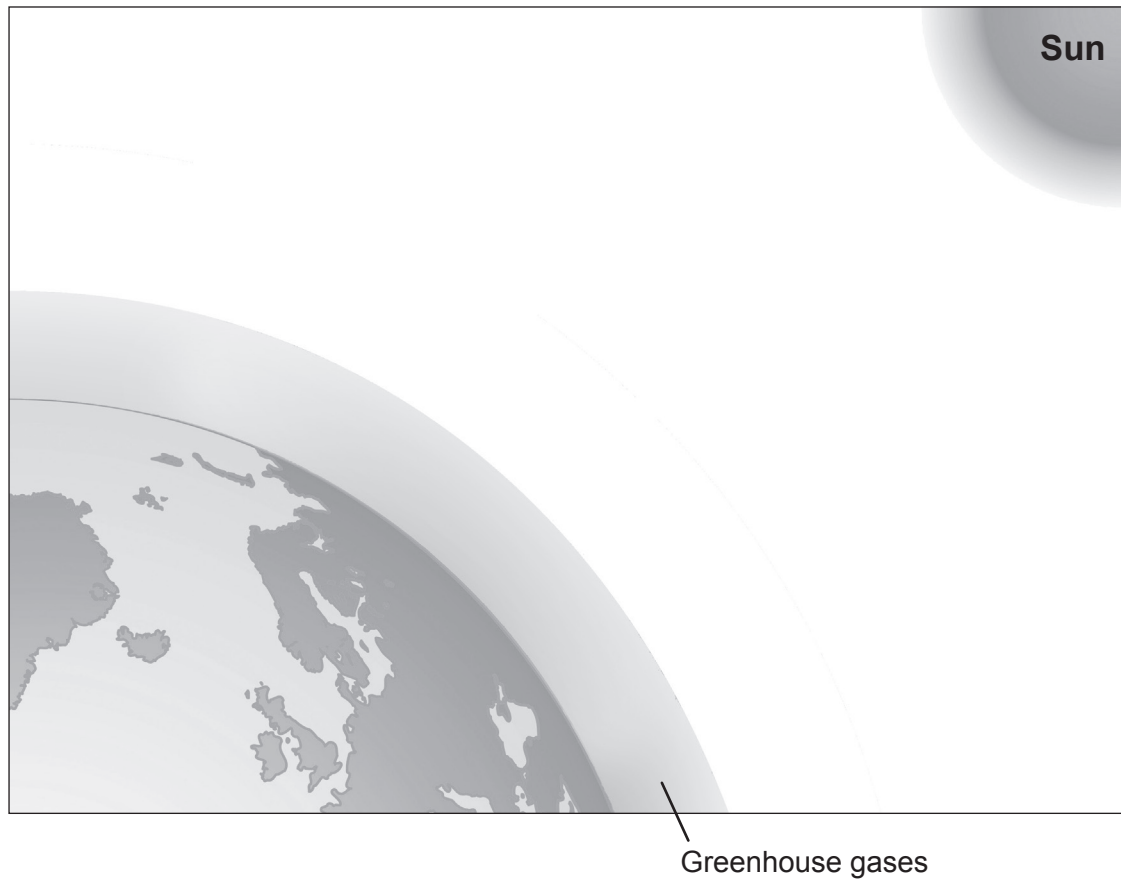

[Source: © International Baccalaureate Organization 2016]

.....

.....

.....

.....

.....

.....

.....

.....

.....

.....



Turn over

4. (a) Label the parts of two paired nucleotides in the polynucleotide of DNA.

[3]

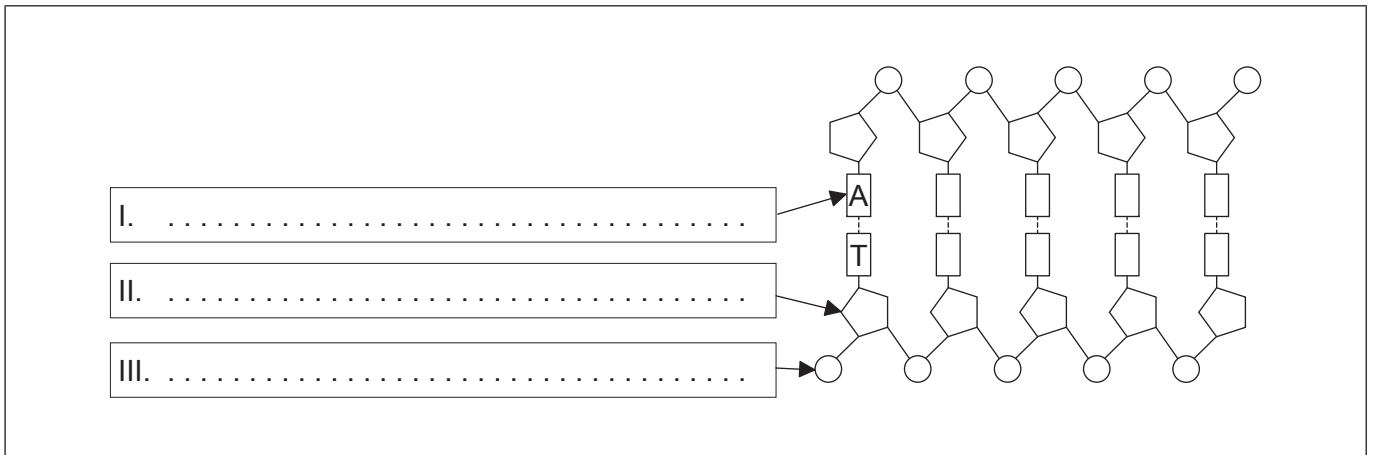

(This question continues on the following page)



(Question 4 continued)

The image shows part of a cladogram.

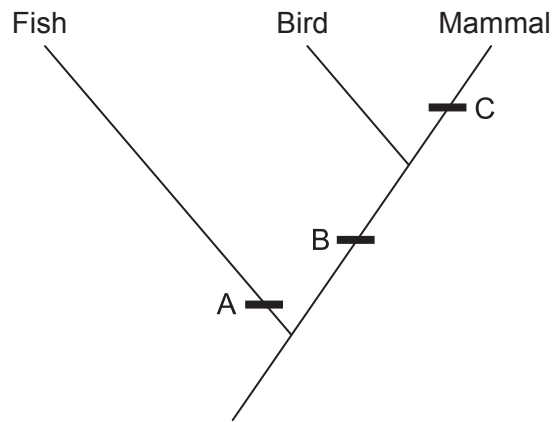

- (b) Using the cladogram, identify **one** diagnostic feature that characterizes the given groups of vertebrates at A, B and C. [3]

A:	.....
B:	.....
C:	.....

- (c) State the name of the domain to which these organisms belong. [1]

.....
-------



### Section B

Answer **one** question. Up to one additional mark is available for the construction of your answer. Write your answers in the boxes provided.

5. (a) Outline the action of enzymes. [4]
- (b) Many genetic diseases are due to recessive alleles of autosomal genes that code for an enzyme. Using a Punnett grid, explain how parents who do not show signs of such a disease can produce a child with the disease. [4]
- (c) Explain the propagation of electrical impulses along a neuron including the role of myelin. [7]
6. (a) Draw a labelled diagram of a eukaryotic plant cell as seen in an electron micrograph. [4]
- (b) Outline the process of gas exchange necessary for aerobic respiration in a unicellular eukaryotic organism. [3]
- (c) Explain how the process of evolution occurs. [8]



Dotted lines for writing.



20EP15

Turn over

A large rectangular area with a dotted grid pattern for writing.



20EP16



A large rectangular area containing horizontal dotted lines for writing.



20EP17

Turn over

A large rectangular box with a dotted line pattern, intended for writing.



Area containing a grid of dotted lines for writing.



20EP19

Turn over

A large rectangular area containing 28 horizontal dotted lines, intended for writing or drawing.



20EP20